

**LAIKO** Laiko Pump (Zhejiang) Co., Ltd.  
PUMP AND SYSTEM SOLUTION PROVIDER

VERSION: 2026.05

**LAIKO**

# EXPLORING THE BEAUTY OF FLOW

No. 689 Xicheng Road,  
Zeguo Town, Wenling City, Taizhou City, Zhejiang Province, China  
🌐 [www.laikopump.com](http://www.laikopump.com)    ✉ [laiko@laikopump.com](mailto:laiko@laikopump.com)

PUMP AND SYSTEM SOLUTION PROVIDER

# LAIKO

PUMP AND SYSTEM SOLUTION PROVIDER



Superior in Pump, Superior in Energy-Saving.



## **LAIKO** Laiko Pump Pump and System Solution Provider

LAIKO Pump(Zhejiang) Co., Ltd. is a subsidiary of Zhejiang Dayuan Pumps Industrial Co., Ltd. (Stock code: 603757), focusing on the research and manufacturing of energy-saving pumps.

LAIKO's applications cover the fields of construction, municipal, and industrial sectors. Currently, we have product lines including Inline Multistage Pumps, Inline Circulation Pumps, Horizontal Multistage Pumps, Cold and Hot Water Circulation Pipeline Pumps, Single-Stage Centrifugal Pumps, Standard Centrifugal Pumps, Stainless steel Horizontal Single-Stage Centrifugal Pumps, Submersible Sewage Pumps, and Immersed Multistage Centrifugal Pumps. Our products are exported to many countries and regions in Europe, America, and Asia, meeting local legal requirements and obtaining recognition from clients.

A standard research and development, production, sales, and service system has laid the core competitiveness and sustainable development space for LAIKO. Reliable product quality and thoughtful after-sales service have earned LAIKO widespread reputation.

LAIKO maintains a pioneering spirit, always adheres to the concept of technological innovation, and never stops exploring energy-saving endeavors!

### **Research and manufacturing of energy-saving pumps, providing pump and system solutions**

With over 34 years of accumulated strength, we have formed an alliance with top domestic water pump research and development, production, sales, and technical teams, Established Zhejiang Laiko Pump Industry Co., Ltd. (referred to as Zhejiang Leike), with comprehensive strength ranking among the top in the industry.

The second-generation green intelligent factory of Industry 4.0 standard covers an area of nearly 200 acres, with an annual output of over 7 million units and a total investment of over 1 billion yuan.

Zhejiang Laiko has established a comprehensive sales and service network nationwide, with direct offices in major cities. Our products are exported to multiple countries and regions in Europe, America, and Asia. China Laiko pumps globally.



Wenling, Zhejiang, China

### **GREEN SMART FACTORY**

Dayuan Pump Group and its subsidiary Laiko Pump Industry have implemented a significant strategic layout. Covering an area of nearly 200 acres with a total investment of approximately 1 billion RMB, the facility has an annual production capacity of 7 million units. It is a modern integrated factory that combines production, research and development, manufacturing, and logistics.



## R&D STRENGTH

<b>346</b> Domestic patents	<b>29</b> Invention Patent	<b>242</b> New utility patent	<b>75</b> Appearance patent	<b>6</b> Overseas patents
--------------------------------	-------------------------------	----------------------------------	--------------------------------	------------------------------

As a brand under Dayuan Pump Group, we have a strong foundation with over 177 R&D personnel and more than 352 patents. Our products have been honored with titles such as "Zhejiang Famous Brand Product" and "Zhejiang Export Famous Brand," and are exported to multiple countries and regions across Europe, America, and Asia. Our comprehensive strength ranks among the top in the industry. Through years of continuous investment in research and development, we have established a significant technological innovation advantage.

## SERVICE COOPERATION

We have established offices in major cities across the country, supported by a professional and efficient service team. From consultation, purchase, after-sales, to maintenance, we provide high-quality, professional, timely, and attentive services at every stage.

Guided by the principle of "wholehearted dedication and customer-first," we respond quickly to customer needs, offering precise product recommendations and tailored solutions. Our comprehensive and full-cycle services ensure a worry-free experience for our customers.

SERVICE TENET: With all our heart and soul, Putting customers first

SERVICE TENET: Rapid response, Precise solution

SERVICE OBJECTIVES: Efficient O&M, Win-Win Cooperation

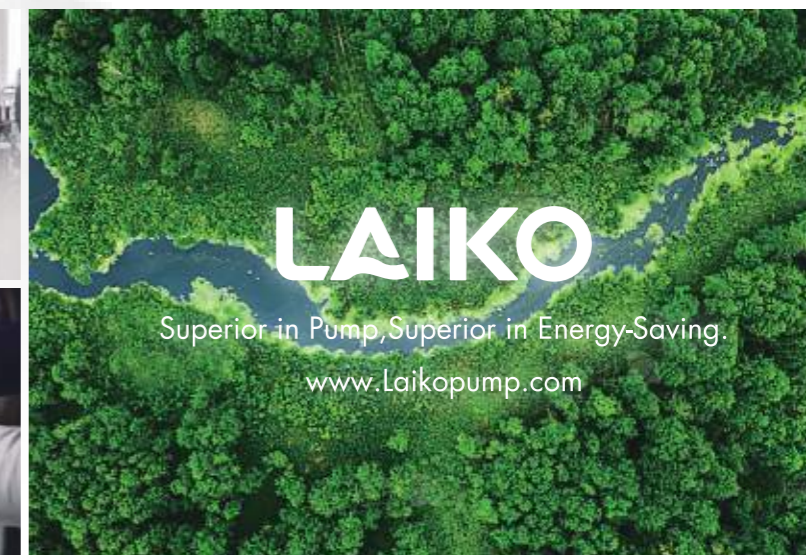

# LAIKO



Application Scenarios in Municipal, Construction, and Industrial Fields

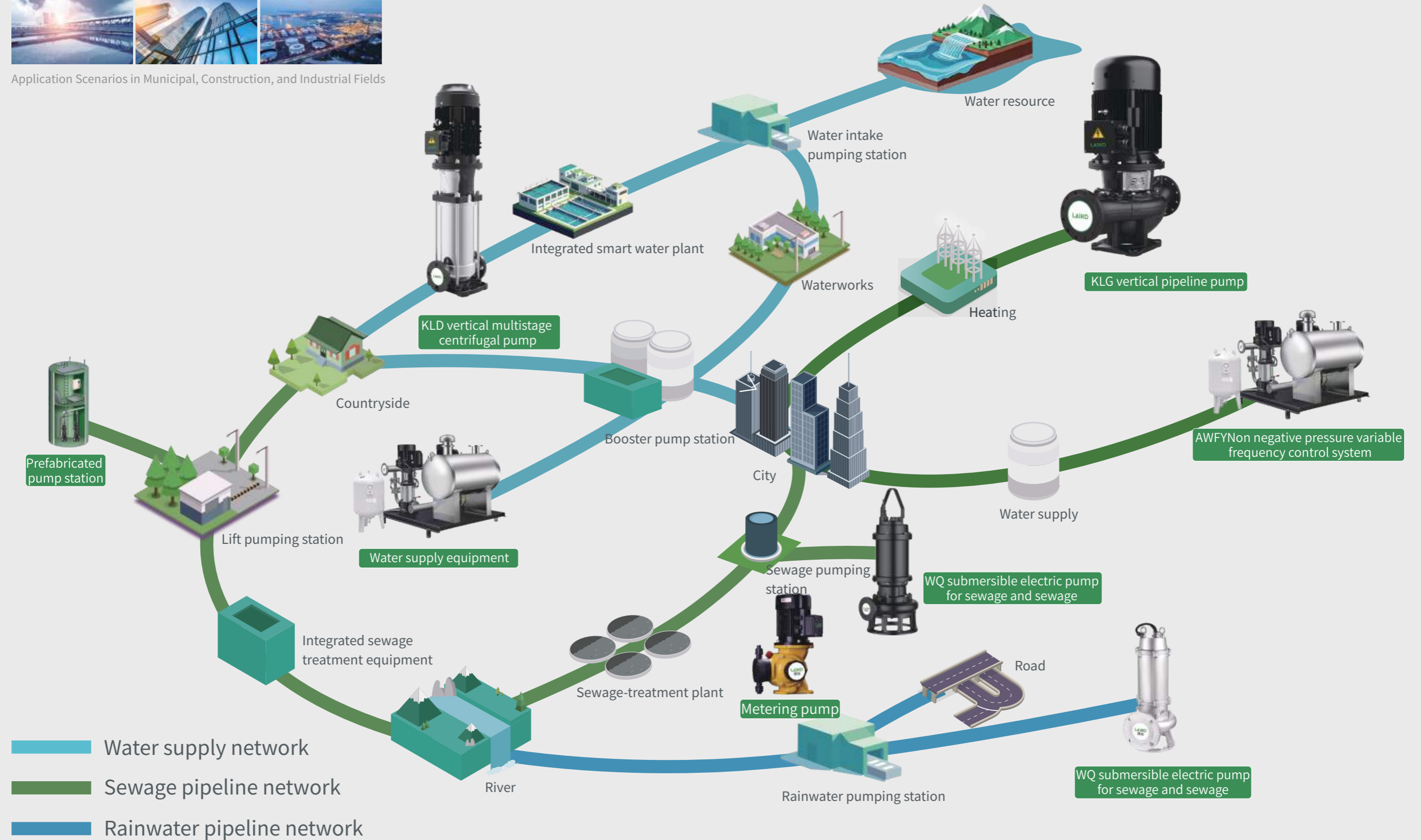

# LAIKO

## KLD/KLDS

SVERTICAL MULTI-STAGE CENTRIFUGAL PUMP SERIES

Newly upgraded | Powerful | Efficient and energy-saving | Durable | EU standard



### TECHNICAL DATA

Flow range:0.4~330m<sup>3</sup>/h Medium pH value:3~9  
Maximum ambient temperature:+40°C Maximum altitude:1000m

## KLD/KLDS

VERTICAL MULTI-STAGE CENTRIFUGAL PUMP SERIES

KLD/KLDS is a brand new hydraulic high-efficiency energy-saving vertical multi-stage centrifugal pump. Referring to EU standards, the MEI value is greater than 0.7, and the cast iron parts are made of global ductile iron. The product has undergone a new industrial design and features higher energy efficiency, lower noise, lower vibration, higher reliability, compact structure, beautiful appearance, and convenient use and maintenance.

Suitable for conveying low viscosity, non flammable, non explosive, and easily vaporized liquids that do not contain solid particles or fibers. The liquid should not have a chemical reaction with the pump material. When the density and viscosity of the conveyed liquid are greater than water, a high-power motor is required. For more details, please consult our company.

### LIQUID TEMPERATURE:

Room temperature type: -20 ° C~+70 ° C

Hot water type: -20 ° C~+120 ° C

Fully enclosed standard air-cooled two pole standard motor

Protection level: IP55

Insulation level: F

### APPLICATION FIELD

Water Supply

Engineering Pressurization

Water Treatment

Irrigation

Food and Beverage

Pharmaceutical Industry

Superior in Pump, Superior in Energy-Saving.

# LAIKO

## CDL/CDLF

VERTICAL MULTI-STAGE CENTRIFUGAL PUMP SERIES

Powerful power | Efficient and energy-saving | Stable and durable |  
Challenging more application scenarios



### TECHNICAL DATA

Flow Range: 0.4~240m<sup>3</sup>/h Head Range: 4~305m Power Range: 0.37~110kW  
Maximum Work Pressure: 33bar

## CDL/CDLF

VERTICAL MULTI-STAGE CENTRIFUGAL PUMP SERIES

The CDL/CDLF series is a high-efficiency non self suction vertical multi-stage centrifugal pump (hereinafter referred to as the pump), which has the characteristics of energy saving, low noise, environmental protection, compact structure, beautiful appearance, light weight, easy use and maintenance, and high reliability. The key overcurrent components are made using processes such as stainless steel stamping, precision laser welding, and stainless steel precision casting.

Low viscosity, non flammable and non explosive liquid that is prone to vaporization, and does not contain solid particles or fibers (CDL is suitable for non corrosive liquids, while CDLF is suitable for mildly corrosive liquids). The liquid should not have a chemical reaction with the pump material. When the density and viscosity of the conveyed liquid are greater than water, a high-power motor is required. For more details, please consult our company.

### LIQUID TEMPERATURE:

Room Temperature Type: -20 °C~+70 °C

Hot Water Type: -20 °C~+120 °C

Medium pH Value: 3~9

Maximum ambient Temperature: +40 °C

Highest Altitude: 1000m

### APPLICATION FIELD

Water Supply

Engineering Pressurization

Water Treatment

Irrigation

Food and Beverage

Pharmaceutical Industry

Superior in Pump, Superior in Energy-Saving.

# LAIKO

## KWD

HORIZONTAL MULTI-STAGE CENTRIFUGAL PUMP SERIES

Powerful Power | Energy saving and Silent | Flexible Adaptation | Safe and Reliable



### TECHNICAL DATA

Flow range:0.4~29m<sup>3</sup>/h Head range:5~87m Power range:0.25~7.5kW

Fully enclosed standard air-cooled secondary standard motor Protection level:IP55 Insulation level:F

## KWD

### HORIZONTAL MULTI-STAGE CENTRIFUGAL PUMP SERIES

KWD is a new generation of non self suction horizontal multi-stage centrifugal pump with a brand new industrial appearance design. The pump adopts axial suction and radial discharge, and the key flow components are made of stainless steel stamping and welding technology. Excellent hydraulic performance and unique structural design, characterized by high efficiency, low noise, low vibration, stability and reliability, resistance to mild corrosion, compact structure, beautiful appearance, small size, light weight, and easy maintenance, achieve efficient operation of fluid transportation in various scenarios, and effectively reduce the operating costs of users' pumps. Operating conditions: a liquid that is thin, clean, non corrosive, non flammable, non explosive, easily vaporized, and does not contain solid particles or fibers; When the density of the conveyed medium is greater than that of clean water, a high-power motor is required. Please consult our company for details.

#### LIQUID TEMPERATURE:

Room temperature type: -20 °C~+70 °C

Hot water type: -20 °C~+105 °C

Maximum operating pressure: 10 bar

Maximum altitude: 1000m

Maximum ambient temperature: +40 °C

Medium pH value: 3~9

Connection method: Threaded/Quick-clamp

#### APPLICATION FIELD

Cooling System

Air Conditioning System

Water Treatment (purification of water)

Industrial Cleaning System

Transport, Circulation, and Lifting of Liquids

Hot and Cold Water

Food and Beverage

Pharmaceutical Industry

Superior in Pump, Superior in Energy-Saving.

# LAIKO

## AWD

HORIZONTAL MULTI-STAGE CENTRIFUGAL PUMP SERIES

Powerful Power | Energy saving and Silent | Flexible Adaptation | Safe and Reliable



### TECHNICAL DATA

Flow range:0.4~28m<sup>3</sup>/h Head range:7.5~66.5m  
Power range:0.37~4kW Maximum working pressure:10bar

## AWD

HORIZONTAL MULTI-STAGE CENTRIFUGAL PUMP SERIES

AWD is a non self suction horizontal multi-stage centrifugal pump, characterized by high efficiency, low noise, resistance to mild corrosion, compact structure, beautiful appearance, small volume, and light weight; The pump adopts axial suction and radial discharge, and the key flow components are made of stainless steel stamping and welding technology. The product is suitable for liquids that are thin, clean, non corrosive, non flammable and non explosive, and do not contain solid particles or fibers; When the density of the conveyed medium is greater than that of clean water, a high-power motor is required. Please consult our company for details.

### LIQUID TEMPERATURE:

Room temperature type: -20 °C~+70 °C  
Hot water type: -20 °C~+105 °C  
Altitude: up to 1000m  
Maximum ambient temperature:+40 °C  
Maximum working pressure: 10 bar

### APPLICATION FIELD

Cooling System  
Air Conditioning System  
Water Treatment (purification of water)  
Industrial Cleaning System  
Transport, Circulation, and Lifting of Liquids  
Hot and Cold Water  
Food and Beverage  
Pharmaceutical Industry

Superior in Pump, Superior in Energy-Saving.

# LAIKO

## ADX/ADZ

HORIZONTAL END SUCTION CENTRIFUGAL PUMP

Strong and stable flow | Efficient and low-noise | Good anti cavitation performance



### TECHNICAL DATA

Maximum flow rate:1200m<sup>3</sup>/h Maximum head:90m  
Maximum working pressure:10bar(16bar/25bar optional) Medium temperature:0°C-120°C  
Maximum ambient temperature:+40°C Maximum altitude:1000m  
import flange:DN50-DN300 export flange:DN32-DN250

# ADX/ADZ

HORIZONTAL END SUCTION CENTRIFUGAL PUMP

The ADZ/ADX series is a non-self-priming, single-stage, single-suction, horizontal pump with axial water inlet and radial water outlet. The bottom of the pump body is fixed to the base. The hydraulic design based on CFD makes it more efficient than conventional products in the market.

The whole pump is designed in 3D and its strength is checked by FEA. The ADZ series motors feature an extended shaft design, which reduces the number of parts and increases reliability. The ADX series features a universal modular design, allowing different bearing housings to be selected according to the actual load of customers.

Standardly equipped with a YE3 motor, it ensures energy conservation and long-term economic operation. The installation dimensions and performance comply with the DIN EN 733 standard. Equipped with standard wear-resistant mechanical seal.

Flange pressure PN 16 complies with DIN 2533 standards (PN25 is optional).

Medium temperature: 0 °C~120 °C

Ambient temperature: up to +40 °C

Altitude: up to 1000m

Maximum working pressure: 10 bar(16bar or 25bar is optional)

### APPLICATION FIELD

Water Supply System  
Heating and Air Conditioning System  
Boosting Water Supply, Constant Pressure Water Supply  
Fire Sprinkler System  
Irrigation and Livestock Use  
Industrial Cooling  
Heating Cycle System Industrial Conveying  
Drain off System



Superior in Pump, Superior in Energy-Saving.

# LAIKO

## AWZ

HORIZONTAL STAINLESS STEEL SINGLE-STAGE CENTRIFUGAL PUMP

Lightweight structure | Efficient and energy-saving |  
Anti corrosion and durable | Long term stability



### TECHNICAL DATA

Flow range:12.5~160m<sup>3</sup>/h Head range: 13.5-66 m  
Maximum working pressure:10bar

## AWZ

### HORIZONTAL STAINLESS STEEL SINGLE-STAGE CENTRIFUGAL PUMP

The AWZ horizontal stainless steel single-stage centrifugal pump is made using advanced processes such as stainless steel plate stamping, bulging, and welding, which can replace traditional corrosion-resistant pumps. It has the characteristics of beautiful appearance, lightweight structure, high efficiency and energy saving, durability, light corrosion resistance, low noise, etc.

The AWZ horizontal stainless steel single-stage centrifugal pump is a versatile product with a wide range of applications. It can transport various media, including water or industrial liquids, and is suitable for different temperature, flow rate, and pressure ranges.

Its typical applications mainly include the following aspects:Clean, thin, non flammable and non explosive liquid, free of solid particles and fibers.

Liquids with temperatures between -20 °C and+100 °C

Environmental temperature: maximum+40 ° C

Highest altitude: 1000m

Maximum system pressure: 10 bar

### APPLICATION FIELD

Water Supply

Industrial Turbocharging

Industrial Liquid Transportation

Weak Acid and AlkaliConveying

System, Machine Tool Matching

Water Treatment

Irrigation of Farmland

Medical Science

Superior in Pump,Superior in Energy-Saving.

# LAIKO

## KLG

VERTICAL PIPELINE PUMP

Powerful Boost | Efficient and Low Noise | Energy saving and Durable |  
Challenging More Application Scenarios



### TECHNICAL DATA

Flow range: 8~900m<sup>3</sup>/h Head range: 9~85m  
Maximum working pressure:12bar(16bar optional)

## KLG

VERTICAL PIPELINE PUMP

The KLG is a new vertical single-stage pipeline centrifugal pump with hydraulic design. The product has undergone ALSYS simulation analysis and innovative industrial design, achieving an energy efficiency index of  $MEI \geq 0.7$ . Some models feature a reduced pipe diameter, offering high efficiency and energy savings as well as high reliability. It can transport various media, from tap water to industrial liquids, primarily serving as a liquid transfer, pressurization, and circulation device. For example: district heating systems (the water quality in the heating system must meet the recognized standards for such systems).

The KLG single-stage pipeline centrifugal pump is equipped with a standard motor and mechanical seal. Compared to similar types of products, its structure is more resistant to the effects of impurities in the pumped liquid. The pump is designed with a top-retractable disassembly form, allowing for maintenance without disrupting the pipeline system. The product is suitable for liquids that are clean, thin, non-corrosive, non-flammable and explosive, and free from any solid particles or fibers that may cause mechanical or chemical damage to the pump. However, when used with highly viscous or dense liquids, it may lead to a decline in pump performance and increased energy consumption. For further details, please consult our company.

Liquid temperature: -15°C to 110°C

Maximum working pressure: 12 bar for the standard type, 16 bar for the special type

Ambient temperature: Maximum +40°C

Altitude: up to 1,000 meters

Rotation direction: Clockwise (looking downward from the motor fan blade end)

### APPLICATION FIELD

HVAC System

Cooling System

Domestic Hot Water System

Industrial Liquid Transportation

Water Supply System

Superior in Pump, Superior in Energy-Saving.

# LAIKO

## ALG

### VERTICAL PIPELINE PUMP

Powerful Boost | Efficient and Low Noise | Energy saving and Durable |  
Challenging More Application Scenarios



#### TECHNICAL DATA

Flow range: 8~900m<sup>3</sup>/h Head range: 9~85m  
Maximum working pressure:12bar(16bar optional)

## ALG

### VERTICAL PIPELINE PUMP

ALG vertical pipeline pump is a multi-purpose product that can transport various media from tap water to industrial liquids. It is mainly used as a liquid transportation, pressurization, and circulation equipment. For example: District heating system (the water quality in the heating system should meet the recognized water quality standards of the system).

ALG type single-stage pipeline centrifugal pump, equipped with standard motor and mechanical seal; Compared with similar types of products, the structure of such products is less susceptible to impurities in the pumped liquid; The product is designed in a top pull-out disassembly form, which can repair the pump without affecting the pipeline system.

The product is suitable for clean, thin, non corrosive, non flammable and non explosive liquids, and does not contain any solid particles or fibers that may cause mechanical or chemical damage to the pump. When used in situations where the liquid is viscous or has a high density, it may cause a decrease in the pump characteristic curve and an increase in energy consumption. For more details, please consult our company.

Liquid temperature: -15 °C~110 °C

Maximum working pressure: 12 bar for conventional models

The special type is 16 bar

Environmental temperature: maximum+40 °C

Altitude: up to 1000m

Rotation direction: clockwise (looking down at the motor fan blade end)

#### APPLICATION FIELD

HVAC System

Cooling System

Domestic Hot Water System

Industrial Liquid Transportation

Water Supply System

Superior in Pump, Superior in Energy-Saving.

# LAIKO

## ASZ

FLUOROPLASTIC CENTRIFUGAL PUMP

Compact structure | Stable performance | Corrosion and corrosion resistance



### TECHNICAL DATA

Flow range: 2.2~60m<sup>3</sup>/h 扬程范围Head range: 20~50m Power range: 1.1~18.5kW

The motor is a fully enclosed, air-cooled two-stage motor

Protection level: IP55 Insulation level: F Standard voltage: 50Hz, 3×380V

## ASZ

FLUOROPLASTIC CENTRIFUGAL PUMP

The ASZ series fluoroplastic centrifugal pump is a single-stage single suction centrifugal pump, with the axial direction being the suction port and the axial direction being the discharge port; Suitable for any concentration of acid, alkali, salt solution, strong oxidant, organic solvent and other highly corrosive media;

The structure is simple, and the pump shaft and impeller are directly connected; Easy to connect, both the inlet and outlet are standard flange connections; The overcurrent components of the pump are made of fluoroplastics (F26, F46), and the auxiliary parts are made of castings (HT200).

A thin medium without solid particles or fibers;

Medium temperature: -20 °C~120 °C

Maximum medium density: 1.35x10<sup>3</sup> kg/m<sup>3</sup>

Maximum ambient temperature: +40 °C

Altitude: up to 1000m

Maximum working pressure :10 bar

### APPLICATION FIELD

Petroleum  
Chemical industry  
Pesticides  
Pickling  
Dyestuff  
Papermaking  
Electroplate

Superior in Pump, Superior in Energy-Saving.

# LAIKO

## WQ

SUBMERSIBLE ELECTRIC PUMP FOR SEWAGE AND SEWAGE

Dual channel design | Efficient sewage discharge |  
Anti blocking and anti-wear | Durable and long-lasting



### TECHNICAL DATA

Structure: In addition to conventional sewage pump structures, cutting or mixing types can be selected.

Flow range: 7~2800m<sup>3</sup>/h Head range: 7~80m Power range: 0.75~250kW

## WQ

### SUBMERSIBLE ELECTRIC PUMP FOR SEWAGE AND SEWAGE

Special cable manufacturing process can completely prevent water from entering the motor through small gaps between wires when the cable skin is damaged or when the front end of the cable is immersed in water; Specially designed submersible motor, IPX8 protection, F-class insulation allows for temperature rise, while the submersible cooling effect is good, the actual temperature rise is low, the motor insulation life is long, and it can ensure that the motor can automatically cut off the power supply in case of abnormal conditions;

Adopting a dual end mechanical seal and an external skeleton oil seal, the oil chamber at the installation of the mechanical seal is specially designed to provide sufficient lubrication even when the oil level is low, extending the service life of the seal and making its sealing performance more reliable, effectively ensuring the safe and continuous operation of the product; The impeller adopts a dual channel design with closed and open shapes, which has good balance, smooth operation, low vibration, and increases the service life of the product. The flow channel has strong ability to pass through, and the measured efficiency is higher than the national standard, saving energy and reducing consumption;

Multiple materials are available, suitable for various media working conditions.

Power supply: 50Hz, three-phase 380V

The temperature of the medium is  $\leq 40^{\circ}\text{C}$  in liquid state, the volume ratio of solid material in the conveying medium is  $< 2\%$ , and the density of the medium is  $< 1200\text{kg/m}^3$

During operation, the minimum liquid level should not be less than 2/3 of the motor's capacity

The diameter of solid objects in the medium shall not exceed the maximum allowable solid diameter

### APPLICATION FIELD

Domestic Sewage

Construction/Municipal Sewage Discharge

Enterprise Sewage Treatment and Circulating Water Transportation

Pumping of Slag Slurry from Factories and Mining Enterprises

Livestock Pumping

Superior in Pump, Superior in Energy-Saving.

# LAIKO

## AIH

SINGLE STAGE SINGLE SUCTION CHEMICAL PROCESS PUMP

Single suction speed flow | Anti corrosion and wear-resistant |  
Stable and durable operation

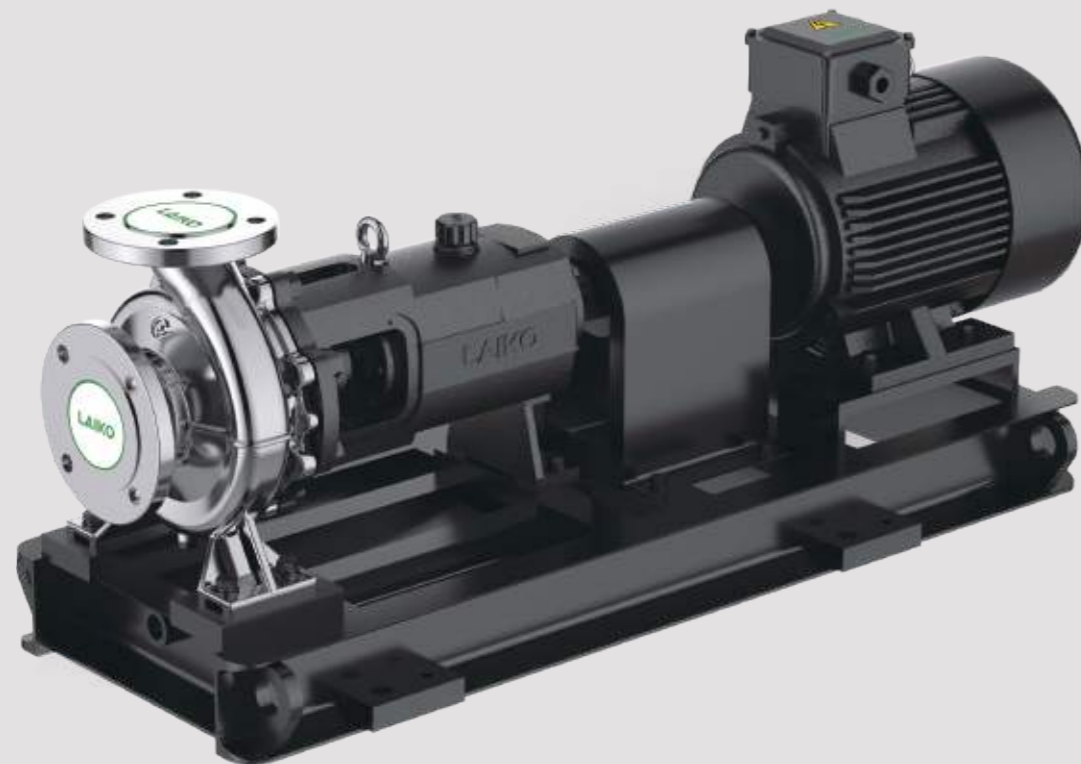

### TECHNICAL DATA

Flow range: 4.8-1200m<sup>3</sup>/h Head range: 10-127m

## AIH

### SINGLE STAGE SINGLE SUCTION CHEMICAL PROCESS PUMP

The AIH series pump is a horizontal single-stage single suction cantilever centrifugal pump, which is optimized, upgraded, and innovated based on the IH pump, IJ pump, and CZ pump currently available in the market. It has a wide range of high efficiency, a wide range of applications, and long bearing spacing, solving the problem of pump shaft breakage in high density and high viscosity media;The hydraulic performance design adopts excellent hydraulic models, optimized through CFD simulation, to improve the efficiency of the pump, which is more than 5% higher than that of IH pumps;The suspension body adopts a bracket support form, which can withstand the stress caused by some pipelines and ensure smooth operation during operation.

The bearing adopts thin oil lubrication and is designed with a bearing isolator. It will not damage the shaft surface during operation and has a service life of up to 25000 hours, avoiding the common maintenance problems of traditional oil seals;Targeted design of the sealing chamber structure has been carried out for media that are prone to crystallization, scaling, and contain solid particles, ensuring the working environment of mechanical seals and improving their service life;The design of the rear blades of the impeller reduces axial force, and the pump body has single and double volute structures to balance radial force and reduce vibration;

Adopting a rear opening design, there is no need to disassemble the inlet and outlet pipelines during maintenance, making it easy to operate and install;Product parts are highly interchangeable, reducing the amount of spare parts stored by users.

The flange standard follows HG/T20592-2009 PN16 RF (can be designed and manufactured according to user requirements using SH/ASTM/ANSI standards, etc.);

When viewed from the drive end towards the pump, it rotates clockwise.

### APPLICATION FIELD

Alkali Production Industry  
Nonferrous Metallurgy  
Petrochemical Industry  
Acid Production Industry  
Pharmaceutical Industry  
Synthetic Fiber  
Plastic Industry  
Fertilizer Industry  
Environmental Protection  
Paper Industry  
Steel Industry

Superior in Pump, Superior in Energy-Saving.

# LAIKO

## KLDS+KLH

HIGH-PRESSURE PUMP

High efficiency and energy saving | Low noise and environmental protection |  
Reliable operation | Strong pressure resistance



### TECHNICAL DATA

Flow range: 4.8-1200m<sup>3</sup>/h Head range: 10-127m

## KLDS+KLH

HIGH-PRESSURE PUMP

KLDS + KLH series are the newly independently developed new-generation, high-efficiency non-self-priming high pressure pumps with reference to European standards.

The products adopt a brand-new industrial design, with energy efficiency indicators reaching  $MEI \geq 0.7$ , and feature energy saving, low noise, environmental protection, compact structure, beautiful appearance, light weight, convenient use and maintenance, and high reliability.

The dual-pump system composed of KLDS + KLH in series can generate a high pressure of 48bar. The first KLDS pump is a feed pump, and the second KLH pump is a specially designed high-pressure pump for high-pressure applications.

The KLH pump is a non-self-priming, vertical multistage centrifugal pump equipped with a standard motor. The rotation direction of the pump is opposite to that of the feed pump, the flow channel cavity is reversed, and the flow direction of the delivered liquid is opposite, so that the pressure-resistant cylinder and mechanical seal only bear the outlet pressure of the feed pump, improving reliability.

It is suitable for thin, clean, non-flammable and explosive liquids that do not contain solid particles, fibers or whose physical and chemical properties are similar to water.

Liquid temperature:

Normal temperature type:  $-15^{\circ}\text{C} \sim 70^{\circ}\text{C}$

Hot water type:  $-15^{\circ}\text{C} \sim 120^{\circ}\text{C}$

Maximum altitude: 1000m

It is a fully enclosed air-cooled two-pole standard motor.

Protection class: IP55

Insulation class: F

When viewed from the drive end towards the pump, it rotates clockwise.

### APPLICATION FIELD

Water treatment ultrafiltration system

Reverse osmosis system

Booster system

High-pressure flushing system

Water supply

Superior in Pump, Superior in Energy-Saving.

# LAIKO

## ALHY(S)

VERTICAL CONSTANT PRESSURE VARIABLE FREQUENCY WATER SUPPLY SYSTEM

Variable frequency precision control | Energy saving and low noise |  
Stable operation | Convenient and durable maintenance



### TECHNICAL DATA

Flow range: 0.4~240m<sup>3</sup>/h Head range: 4-240m Power range: 0.37-18.5kW  
Protection level: IP55 Output frequency range: 30-50Hz

## ALHY(S)

### VERTICAL CONSTANT PRESSURE VARIABLE FREQUENCY WATER SUPPLY SYSTEM

The ALHY (S) series vertical constant pressure variable frequency water supply system is equipped with an intelligent variable frequency controller, which can achieve intelligent control functions such as constant pressure and constant pressure difference by connecting pressure sensors. It has the characteristics of energy saving, low noise, intelligence, environmental protection, compact structure, beautiful appearance, light weight, easy use and maintenance, and high reliability. The pump is equipped with accessories such as variable frequency controller, pressure sensor, stabilizing tube, five way valve, pressure gauge, etc. at the factory, and does not require customer installation.

Low viscosity, non flammable and non explosive liquid that is prone to vaporization, and does not contain solid particles or fibers. The liquid should not have a chemical reaction with the system materials. When the temperature of the transported liquid exceeds 70 °C, please consult our company.

Voltage: Three phase 380VAC  
Medium temperature: 0~70 °C  
Environmental temperature:+40 °C  
Highest altitude: 1000m

### APPLICATION FIELD

Water Supply  
Industrial Turbocharging  
Industrial Liquid Transportation  
HVAC System  
HVAC

Superior in Pump, Superior in Energy-Saving.

# LAIKO

## AWHY

YHORIZONTAL CONSTANT PRESSURE VARIABLE FREQUENCY WATER SUPPLY SYSTEM

Stable performance | Efficient energy saving | Low noise | Corrosion resistance



### TECHNICAL DATA

Flow range: 0.8~17m<sup>3</sup>/h Head range: 6.2-64m Power: 0.37-2.2kW Protection level: IP55

Input power supply: 50Hz 3\*380V±5% Output frequency range: 30-50Hz

## AWHY

### HORIZONTAL CONSTANT PRESSURE VARIABLE FREQUENCY WATER SUPPLY SYSTEM

The AWHY series horizontal constant pressure variable frequency water supply system adopts the technology of variable frequency speed regulation and automatic control, with the efficient and energy-saving AWD non self suction lightweight horizontal multi-stage centrifugal pump. The main components of the system include the AWD pump controller, sensor, pressure tank, five-way check valve, and pressure gauge. It features stable performance, high efficiency, energy saving, fully automatic intelligent control, noise, corrosion resistance, compact structure, beautiful appearance, small size, and light weight.

It is suitable for liquids with low viscosity, thin, clean, nonrosive, non-flammable, non-explosive, and free of solid particles and fibers. When the density of the transported medium is greater than that of water, a high-power motor needs to be equipped. For details, consult us please.

Liquid temperature: -20°C~ 85°C

Maximum operating pressure: 10bar

Maximum altitude: 1000m

Maximum ambient temperature: 40°C

### APPLICATION FIELD

Boiler Feedwater System

Industrial Water Circulation System

Cooling Water System

Urban Residential Household Water Supply System

Superior in Pump, Superior in Energy-Saving.

# LAIKO

## AWFY

NON NEGATIVE PRESSURE VARIABLE FREQUENCY WATER SUPPLY SYSTEM

Latest intelligent control technology | Efficient and energy-saving |  
Safe and durable operation



### TECHNICAL DATA

Flow range: 1~1000m<sup>3</sup>/h Head range: 4~305m

## AWFY

### NON NEGATIVE PRESSURE VARIABLE FREQUENCY WATER SUPPLY SYSTEM

AWFY constant pressure variable frequency water supply, directly connected to municipal tap water for pressurized operation, equipped with a vacuum suppressor detection system to prevent negative pressure on the municipal tap water pipeline network.

Fully automatic operation without human supervision: The system adopts the latest performance intelligent control technology for fully automatic control;

Adjusting the constant water pressure: With intelligent frequency conversion technology, the speed and number of water pumps are automatically adjusted to maintain a constant pressure in the pipeline network, ensuring that the entire water supply system always maintains the optimal state of high efficiency and energy conservation;

Stacked operation, significant savings effect: fully utilizing the pressure of the municipal pipeline network, stacked operation, combined with the performance curve of the water pump itself, automatically optimizes and adjusts, so that each water pump always operates at the high-efficiency point, effectively saving electricity;

Safe operation without negative pressure: using vacuum suppressors to monitor pressure and water level in real-time, and remotely monitoring warning prompts;

Health and safety: All overcurrent components of the equipment are processed with food grade stainless steel materials, fully complying with water related hygiene regulations;

Longer service life: The equipment pipeline is processed using high-precision laser numerical control technology, combined with automatic welding technology, to perfectly create pipeline hardware. Together with internationally renowned low-voltage components, it ensures a longer service life of the equipment.

### APPLICATION FIELD

Water Dispatching

Residential Water Use

Commercial Water Supply

Water Supply in Public Places

Industrial Water

Vegetation Water Use

Public Transportation Water Supply

Superior in Pump, Superior in Energy-Saving.

# LAIKO

## ALJ/ALJ

SIMMERION MULTI-STAGE CENTRIFUGAL PUMP

Intelligent protection technology | Efficient, stable, and durable |  
Challenging more application scenarios



### TECHNICAL DATA

Flow range: 0.4~55m<sup>3</sup>/h Head range: 6~305m

## ALJ/ALJS

IMMERSION MULTI-STAGE CENTRIFUGAL PUMP

ALJ/ALJS is a non-self-priming vertical multistage centrifugal pump designed for installation with a standard motor. The motor shaft is directly connected to the pump shaft through the pump head with a coupling. The pump can be equipped with an intelligent protector if needed, which effectively protects the against dry running, phase loss, overload and so on. To meet the installation depth of the water tank or container, an empty chamber can be installed to change the length of the pump itself. The motor is fully enclosed, air-cooled, two-pole standard motor.

Protection class:IP55

Insulation class:F

Thin, clean, non explosive liquid free of solid particles and fibers, capable of transporting water, cooling water solutions, and cutting lubricants.

Liquid temperature:

Room temperature type -15 °C~+70 °C

Hot water type -15 °C~+120 °C

### APPLICATION FIELD

Electrical Spark

Machining Center

Tapping Center

Iron Chip Conveyor

CNC Lathe

Cooling System

Industrial Cleaning Equipment

Filtration System

Superior in Pump, Superior in Energy-Saving.

# LAIKO

## AG(SS/LS/DS/MS/BS/XS)

MECHANICAL DIAPHRAGM METERING PUMP

High precision and reliability | Smooth and durable operation | Easy to maintain



### TECHNICAL DATA

Flow range: 2~1800L/h

Pressure range: 0.3~1.2MPa Power: 0.25~0.75kW Adjustment ratio: 10:1 Steady-state accuracy:  $\pm 2\%$

The suction lift height can reach 3 meters of water column Maximum suction pressure: 2bar

The maximum allowable temperature of the material.: 40°C

## AG(SS/LS/DS/MS/BS/XS)

### MECHANICAL DIAPHRAGM METERING PUMP

#### Hydraulic end

It's equipped with a mechanically driven diaphragm. There is no diaphragm protection plate on the material side, which facilitates the passage of materials.

Multiple pump head materials such as PVC, PVDF, and 316SS are available for selection, making the pump suitable for conveying various materials.

It has a self-cleaning check valve structure, which is convenient for maintenance.

#### Drive end

The drive end comes in various structural forms (cam structure, eccentric mechanism, double-cam structure, variable eccentric adjustment mechanism), which can be adapted to a variety of harsh working conditions. It's easy to disassemble and convenient to repair.

It operates smoothly, reliably and noiselessly, with low maintenance costs.

Ambient temperature: +40°C

Maximum altitude: 1000m

#### APPLICATION FIELD

Reverse Osmosis (ultrafiltration)

Industrial Water and Wastewater

Environmental Protection

Petrochemical Industry

Oil Refining

Electric Power

Metallurgy

Pharmaceuticals

Food Industry

Water Treatment

Swimming Pool

Seawater Desalination

Superior in Pump, Superior in Energy-Saving.

# LAIKO

## AFROYS/AJMXS

HYDRAULIC DIAPHRAGM METERING PUMP

Precise structure | High safety | Corrosion resistance



### TECHNICAL DATA

Maximum flow rate: 329L/h Maximum discharge pressure: 211bar

Adjustment range: 30%~100% Steady-state accuracy:  $\pm 1\%$

The suction lift height can reach 3 meters of water column

# AFROYS/AJMXS

HYDRAULIC DIAPHRAGM METERING PUMP

The hydraulically driven diaphragm features uniformly distributed loads and a relatively long service life.

It's protected by an internal safety valve for pressure relief, resulting in a low maintenance rate.

It offers zero leakage and can accurately convey high-pressure/high-risk media.

It has a precise structure and high machining accuracy.

Multiple pump head materials are available for selection, making it suitable for various media and working conditions.

It can be equipped with a diaphragm rupture alarm, ensuring high safety.

Ambient temperature: +40°C

Maximum altitude: 1000m

### APPLICATION FIELD

Environmental Protection

Petrochemical Industry

Desulfurization and Denitrification

Oil Refining

Electric Power

Metallurgy

Pharmaceuticals

Food Industry

Water Treatment

Superior in Pump, Superior in Energy-Saving.

# LAIKO

## GW

PIPELINE SEWAGE PUMP

Efficient discharge | Stable operation | Durable and reliable | Strong adaptability



### TECHNICAL DATA

Flow rate: 8~2600m<sup>3</sup>/h Head: 7~60m Power: 0.75~250KW

## GW

PIPELINE SEWAGE PUMP

GW inline sewage pump is a new developed pump on the basis of the characteristics of domestic pump and other advanced foreign technology. It uses the same hydraulic model as QW sewage pump. It has saving energy effect, anti-winding, non-clogging and other characteristics. It has the unique effect on the discharge of solid particles and long fibers junk.

This series pump adopts special impeller structure and new mechanical seal, and it can transport solid matter and long fibers. Compared with the traditional impeller, the impeller of the pump adopts single or double flow pass which is similar as a same size cross-section of the bent pipe. It has very good throughflow ability. With a reasonable vortex room, the pump has high-efficiency. The balance test of the impeller ensures that the pumps works without vibration.

The pump has advanced and mature hydraulic performance. After the products have been tested, it reached all related standards. It makes a lot of customers' admiration by its unique efficiency, reliable performance and stable quality.

### APPLICATION FIELD

Industry and Commerce Heavily Polluted Waste Water  
Municipal Sewage Water Treatment Plant Drainage System  
Residential Sewage Drainage Station  
People Protection System Drainage Station  
Hospital and Hotel Sewage Drainage Discharge  
Public Works and Construction Sites  
Mining Exploration Support Machine Attached  
Country Methane Tank and Farmland Irrigation  
Water Supply Equipment of Water Works

Superior in Pump, Superior in Energy-Saving.

# LAIKO

## ZW

SELF SUCTION UNOBSTRUCTED SEWAGE PUMP

Self suction convenience | Anti corrosion and wear-resistant | Stable and durable | Safe and reliable



#### TECHNICAL DATA

Flow rate: 8m<sup>3</sup>/h~1200m<sup>3</sup>/h Head: 10~80m

Temperature: ≤80°C self-priming: 5m

## ZW

### SELF SUCTION UNOBSTRUCTED SEWAGE PUMP

The ZW series self-priming non-clogging submersible sewage pump is a newly structured product successfully developed based on repeated studies of similar technologies at home and abroad.

This pump integrates self-priming and non-clogging sewage discharge functions. It adopts the axial backflow external mixing method. Through the unique design of the pump body and impeller flow channels, it doesn't need to install a bottom valve or fill with priming water like an ordinary self-priming clean water pump. Moreover, it can suck and discharge liquids containing large solid particles and long-fiber impurities.

Compared with similar domestic products, this pump features a simple structure, good self-priming performance, strong sewage discharge capacity, high efficiency and energy saving, and is convenient to use and maintain.

#### Scope of use:

The ambient temperature should be ≤ 50°C, and the medium temperature should be ≤ 80°C. For special requirements, it can reach 200°C(customized mechanical seal with external flushing water cooling is required).

The specific gravity of the medium should not exceed 1,240 kg/m<sup>3</sup>.

Regarding the pH value of the medium, it ranges from 6-9 for cast-iron materials and from 2-13 for stainless steel.

The self-priming height should not exceed the specified value(4-5 meters). It's advisable that the total length of the suction pipe is ≤ 10 meters. (Water temperature: 20°C, standard atmospheric pressure).

The diameter of the suspended particles that the pump can pass through is 60% of the pump's caliber, and the length of the fibers is 5 times the pump's caliber.

When the medium temperature is relatively high, the self-priming height and the length of the suction pipe need to be reduced.

#### APPLICATION FIELD

Industrial water and Wastewater

Environmental Protection

Metallurgy

Printing and Dyeing

Municipal Sewage Treatment

Superior in Pump, Superior in Energy-Saving.

# LAIKO

## ALT/ALTS

VERTICAL COOLING TOWER DEDICATED PUMP

Efficient cooling | Low noise and stable operation | Convenient and durable maintenance



### TECHNICAL DATA

Flow rate: 30m<sup>3</sup>/h~300m<sup>3</sup>/h Head: 3.1~8.1m

## ALT/ALTS

VERTICAL COOLING TOWER DEDICATED PUMP

ALT,ALTS vertical cooling tower dedicated pump is a large-flow low-head pump, with a head range of 3~12m and vertical installation. The pump uses a knife-edge type of wear-resistant mechanical seal, ensuring reliable operation and long service life. It features compact structure, stable operation, low noise, small size, and easy maintenance.

The ALT pump shaft and motor shaft are connected coaxially; ALTS uses a direct-connected extended shaft structure.

Transporting non-flammable, non-explosive, non-corrosive liquids without solid particles or fibers  
Liquid temperature: -15°C~100°C  
Ambient temperature: up to 40°C  
Maximum working pressure: 6bar

### APPLICATION FIELD

Closed Cooling Tower  
Water Circulation of Condenser  
Unit Equipment Cooling  
Water Supply

Superior in Pump, Superior in Energy-Saving.

# LAIKO

## AWT/AWTS

HORIZONTAL COOLING TOWER DEDICATED PUMP

Efficient cooling | Low noise and stable operation | Convenient and durable maintenance



### TECHNICAL DATA

Flow rate: 30m<sup>3</sup>/h~300m<sup>3</sup>/h Head: 3.1~8.1m

## AWT/AWTS

HORIZONTAL COOLING TOWER DEDICATED PUMP

The pump is non-self-priming, single-stage, single-suction, horizontally mounted, with axial water intake and radial water discharge. The motor is fixed to the base, eliminating the need for additional support installation at the pump end, making installation convenient.

It adopts a rear-pull structure, making maintenance convenient.

The AWT pump shaft and motor shaft are connected coaxially, occupying a small area and having a light weight. AWTS adopts a direct elongated shaft structure.

The impeller and pump body are designed with excellent hydraulic models, and the optimal operating conditions are customized according to market demand, resulting in high efficiency.

The key components such as the impeller and pump shaft are all made of stainless steel.

The casting adopts resin sand casting process, with smooth surface, good appearance quality, and dense structure.

The product is suitable for clean, thin, non-corrosive, non-flammable, and explosive-free liquids that do not contain any particles or fibers that could cause mechanical or chemical damage to the pump. The pump performance curve will decrease and the energy consumption will increase if it's used in liquids with high viscosity or density.

Liquid temperature: -15°C~100°C

Ambient temperature: up to 40°C

Maximum working pressure: 6bar

The motor is fully enclosed and air-cooled.

Protection class: IP55

Insulation class: F

Standard voltage: 50Hz: 1×220V

3×380V

### APPLICATION FIELD

Closed Cooling Tower

Water Circulation of Condenser

Unit Equipment Cooling

Superior in Pump, Superior in Energy-Saving.

# LAIKO

## JET PUMP

HORIZONTAL COOLING TOWER DEDICATED PUMP

Exquisite design | Powerful suction | Durable | Widely applicable



### TECHNICAL DATA

Flow rate: 0m<sup>3</sup>/h~6.5m<sup>3</sup>/h Head: 0~55m

# JET PUMP

## HORIZONTAL COOLING TOWER DEDICATED PUMP

The JET series jet pumps are water supply systems suitable for household water withdrawal, well water lifting, pipeline boosting, agricultural irrigation, vegetable greenhouse, garden irrigation, and livestock farming, etc.

The JET-DP series deep well jet pumps are suitable for agricultural irrigation, garden sprinkling irrigation, vegetable greenhouse water supply, and drainage in husbandry, as well as deep well water lifting and other household automatic water supply occasions.

The conveyed medium is a liquid at ambient temperature, clean, non-corrosive, and free of solid particles or fibers. Its pH value is between 6.5-8.5. The power supply requirements are a frequency of 50Hz, a rated voltage of 220V(three-phase 380V).

### APPLICATION FIELD

Water Supply and Drainage Systems such as River Water and Well Water  
High Rise Buildings Water Supply  
Pipeline Pressurization  
Agricultural Irrigation  
Garden Irrigation  
Breeding Industry

Superior in Pump, Superior in Energy-Saving.



**Focus on professionalism Green innovation**  
**Efficient execution Win win cooperation**

Offices have been established in major cities across the country, with professional and efficient service teams providing efficient, professional, timely, and caring services throughout the entire process, including consultation, purchasing, after-sales, and maintenance. Adhering to the spirit of "wholeheartedly, customer first", we respond quickly to needs, provide accurate product recommendations and solutions for customers, offer more targeted services, and provide worry free services in all aspects and cycles.



**Pre sales 520 service**

Committed to providing customers with efficient, professional, and high-quality experiences. From receiving customer inquiries, respond quickly within 5 minutes (establish communication with customers, understand needs), rely on the team's rich experience and professional knowledge, provide constructive solutions within 20 minutes, accurately match customer needs, provide strong support for customer decision-making, and efficiently and professionally assist in the smooth development of business.

**Selling 4 full services**

Adhering to the four "all" concepts, the contract is fulfilled throughout the entire process, and all terms are strictly implemented; the goods are tracked throughout the process, and logistics updates are promptly provided; the products are guaranteed throughout the process to ensure worry free quality; and the service is provided with peace of mind, with a professional team responding at any time to eliminate any worries for you.

**After sales service 3121**

Adhere to an efficient and responsible attitude, respond quickly within 30 minutes upon receiving problem feedback, provide a troubleshooting plan within 1 hour, and preliminarily solve the problem within 2 hours. Everything is customer-oriented, uphold an efficient and responsible attitude, continue to follow up until the problem is completely resolved, and satisfy the customer.



**Laiko Pump Industry  
National Service Office**



- Beijing Office
- Tianjin Office
- Shijiazhuang Office
- Taiyuan Office
- Xian Office
- Zhengzhou Office
- Chengdou Office
- Wuhan Office
- Hefei Office
- Changsha Office
- Kunming Office
- Foshan Office
- Zhongshan Office
- Guangzhou Office
- Shenzhen Office
- Dongguan Office
- Qingdao Office
- Zibo Office
- Weifang Office
- Yantai Office
- Changqing Office
- Dezhou Office
- Jining Office
- Jinan Office
- Nanjing Office
- Wuxi Office
- Suzhou Office
- Shanghai Office
- Huzhou Office
- Jiaxing Office
- Ningbo Office
- Huangzhou Office
- Wenzhou Office
- Fuzhou Office
- Xiamen Office

**Headquarters  
(Taizhou)**

With all our heart and soul, Putting customers first

Tel: 4008-603-757  
[www.laikopump.com](http://www.laikopump.com)

# LAIKO

Partial cooperative enterprise brands  
(ranked in no particular order)

 <b>川润股份</b> CRUN LTD 风电 四川川润液压润滑设备有限公司	 <b>国机集团</b> SINOMACH 机械工业 中国联合工程有限公司	 <b>FINEBEY</b> 环保设备 湖南凡贝环境设备有限公司	 <b>中信集团</b> CITIC Group 中央金融 中国中信集团有限公司	 <b>中国电建</b> POWERCHINA 水力水电工程 中国水利水电第十四工程局有限公司
 <b>冰轮环境</b> MOON-TECH 制冷空调/环保节能技术 冰轮环境科技股份有限公司	 <b>探勘集团</b> 市政工程 深圳市勘察测绘院(集团)有限公司	 <b>南方环境</b> 环保服务 南方环境有限公司	 <b>万山集团</b> WANSHAN GROUP 建筑材料 山东万山集团有限公司	 <b>浙江正蓝</b> 节能环保技术研发 浙江正蓝节能科技股份有限公司
 <b>ZISEN 正升环保</b> 环保处理工程 四川正升环保科技有限公司	 <b>坤奕环境</b> KUNYEE ENV 环境治理 江苏坤奕环境科技股份有限公司	 <b>重庆港力</b> 环境污染治理 重庆港力环保股份有限公司	 <b>温克</b> 智能装备控制 温克控股集团股份有限公司	 <b>汇贤优策</b> 智能·节能技术 重庆汇贤优策科技有限公司
 <b>托普云农</b> 农业领域 浙江托普云农科技股份有限公司	 <b>万德斯</b> WONCLIX 环保节能设备制造 南京万德斯环保科技有限公司	 <b>vanke</b> 地产类 万科企业股份有限公司	 <b>河南双鑫</b> 环保设备 河南双鑫消防环保设备制造有限公司	 <b>Molecular</b> 摩尔 水处理设备 重庆摩尔水处理设备有限公司
 <b>洁能</b> 环保水处理设备制造 广州洁能建筑设备有限公司	 <b>Transfar</b> 化工制品 浙江传化化学品有限公司	 <b>DONGLIANG</b> 有色金属冶炼和压延加工业 栋梁铝业有限公司	 <b>Orient</b> 境外能源工程 浙江国贸集团东方机电工程股份有限公司	 <b>中国节能</b> CECEP 节能环保 中国节能环保集团有限公司
 <b>大张过滤</b> 过滤设备 大张过滤设备有限公司	 <b>TIESSC</b> 金属加工 滕州市泰翔机械有限公司	 <b>龍鳳山</b> 铸造生铁 河北龙凤山新材料科技集团有限公司	 <b>山东北澳</b> 化工 山东北澳化工有限公司	 <b>XIZI</b> 西子联合工程 工程解决方案 浙江西子联合工程有限公司
 <b>大禹节水</b> 水利水电工程 大禹节水集团股份有限公司	 <b>CASIC</b> 环保 航天凯天环保科技股份有限公司	 <b>NE</b> 科研平台 东莞新能源研究院	 <b>山东招金</b> 水务工程 山东招金膜天股份有限公司	 <b>景津装备</b> 过滤装备制造 景津装备股份有限公司
 <b>ZJTM</b> 计量检定机构 浙江省计量科学研究院	 <b>浙江省能源集团</b> 能源产业 浙江省能源集团有限公司	 <b>德环环保</b> 水处理工程 江苏德环环保集团有限公司	 <b>石药集团</b> CSPC 药物 石药控股集团有限公司	 <b>华立供水</b> 水处理设备 山东华立供水设备有限公司

PUMP AND SYSTEM SOLUTION PROVIDER